

AlphaJoint C

DATASHEET ISSUE 1.5
11 January 2010

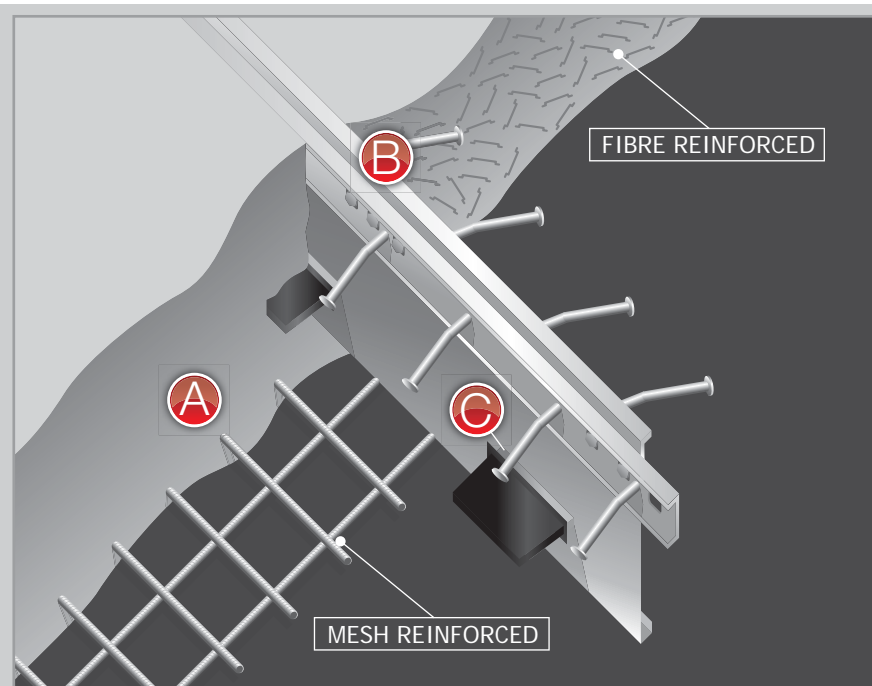

A: Slab Depth	B: AlphaJoint C to suit
	Standard heights available
130 - 150mm	GJC-5D-120
140 - 160mm	GJC-5D-130
150 - 170mm	GJC-5D-140
160 - 180mm	GJC-5D-150
170 - 190mm	GJC-5D-160
180 - 200mm	GJC-5D-170
190 - 220mm	GJC-5D-180
210 - 240mm	GJC-5D-200
235 - 265mm	GJC-5D-225
260 - 290mm	GJC-5D-250
285 - 315mm	GJC-5D-275
310 - 340mm	GJC-5D-300

see notes

! For slab depths less than 130mm or greater than 340mm please contact Permaban.

C: GD8 Plate Dowel

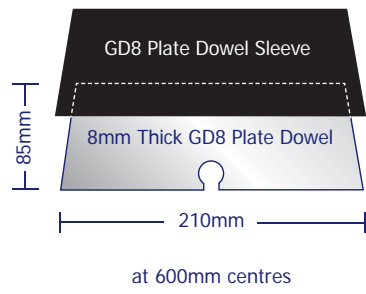

! For steel fibre reinforced slabs greater than 225mm thick we recommend the use of AD10. GD8 may be used if the slab has been designed by an engineer such that the Ultimate Load per metre at the joint will not be exceeded.

UK Patent No. 0811427.4

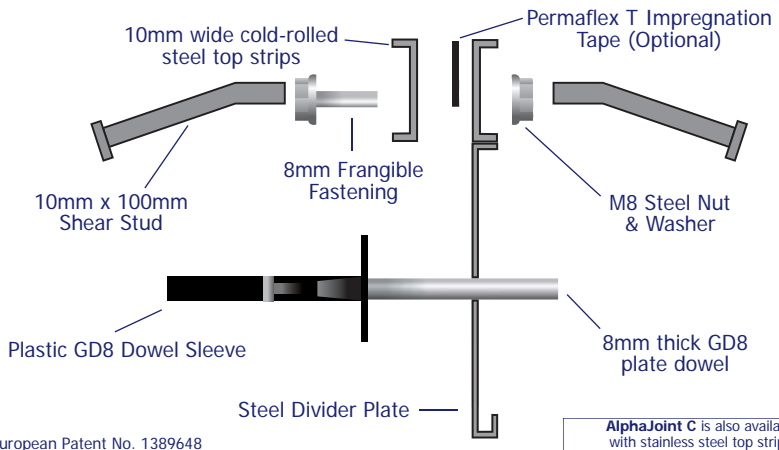

European Patent No. 1389648

AlphaJoint C is also available with stainless steel top strips.

APPLICATION:

- For heavy-duty applications on jointed, jointless, steel fibre or mesh reinforced ground bearing and suspended floor slabs on piles, bar or steel fibre reinforced.
- For joint opening up to 20mm maximum.
- For openings possibly greater than 20mm, refer to AlphaJoint 4010 AD10 or AlphaSlide.

! We recommend that load transfer is calculated for all slabs by the engineer.

FEATURES:

- 'Leave-in-place' steel formwork system with 2 x 10mm wide x 40mm cold rolled steel top strips mounted on a steel divider plate.
- Unique 'C' shape cross section profile top strips.
- Profile has sharp corners in contact with concrete to prevent spalling.
- Cold rolling process work hardens the steel enhancing durability.
- Sustainable design with 60% weight saving over solid 40mm x 10mm profile.
- 8mm thick GD8 Plate Dowels and Sleeves at 600mm centres provides load transfer across the joint.
- 10mm diameter x 100mm long shear studs induction welded to the 10mm wide steel strips.
- Frangible fastening system.
- Simple end to end lapped connection.
- Installation by AlphaFix, AlphaFoot or pins
- Pre-fabricated 4way intersections, T junctions and corner units.
- Available with Permaflex T Tape System pre-installed.

BENEFITS:

- The 10mm wide steel strips provide heavy-duty joint edge (arris) armoured protection which significantly reduces the joint maintenance requirement compared to other joint types.
- Joint load transfer by GD8 Plate Dowel is superior to round dowels and allows 2-way lateral movement, negligible vertical movement between adjacent slabs (4 times less than any other joint tested) and 4 times greater joint stiffness at 20mm joint opening.
- Shear studs firmly anchor the steel strips into the concrete and resist rotation of the strip from wheel impact.
- Lapped end bolted connection speeds up accurate installation and eliminates site welding.
- Re-useable AlphaFix installer facilitates very accurate floor levels to be achieved with the simple micro height adjustable levelling system.
- All vulnerable floor joint intersections are properly armoured by pre-fabricated sections.
- Permaflex T Tape System opens as the joint opens and can be filled with Permaflex Impregnation Sealant.



PERMABAN LIMITED

Mill Close, Lee Mill Industrial Estate,
Ivybridge, Devon PL21 9GL

t: +44 (0)1752 895288 f: +44 (0)1752 690535

Permaban Limited are registered in England - No. 02815314

AlphaJoint C

DATASHEET ISSUE 1.5
11 January 2010

The load transfer from one concrete panel to the adjacent panel has traditionally been by the use of round steel dowels across the joint. Round dowels do not allow lateral movement which was not generally appreciated as required until the development of plate dowels allowed lateral movement and also provided a better load transfer efficiency.

When the 'Ultimate Load' (see table 1) is reached, failure of the dowel or concrete will occur. The failure mode of the dowel will be either by shear or bending or a combination (see table 1) of the two. However, it is more likely that the concrete will fail due to bearing or bursting.

A number of factors determine the Ultimate Load. These factors are concrete strength, joint opening, slab depth, the improvement to the concrete flexural strength provided by the reinforcement

(steel mesh or steel fibre) at the area of the joint (the Re3 factor), geometry of the dowel, dowel steel strength at yield, thickness of the dowel, the amount of embedment of the dowel in the concrete and the dowel centres. Some of these factors are fixed by the product design, such as the factors relating to the dowel i.e dowel geometry, dowel centres and dowel steel strength.

However, the other factors outlined above will vary with the slab design and influence the Ultimate Load. The table below indicates the theoretical calculated Ultimate Load per dowel, concrete limit and Ultimate Load per metre for three typical slab thicknesses, non-reinforced and reinforced with steel fibres to achieve RE3 = 0.8.

Please contact Permaban for details of our AD10 plate dowel system where an application requires higher Ultimate

Loads per dowel. For extra heavily loaded joints in excess of the loads in Table 1 on ground bearing or suspended slabs additional reinforcement can be incorporated into the joint at extra cost. Alternatively for mesh slabs the engineer may wish to consider steel fibre edge reinforcement. Specifying engineers should carry out their own joint load transfer check, in accordance TR34 3rd Edition.

For slabs suspended on piles, each slab must be designed taking into account the ultimate load transfer capacity of the joint. As a general rule of thumb, where the distance between the applied concentrated load and the joint exceeds 1 metre and the working load does not exceed either a 'back-to-back' rack leg load of 60kN/leg or a single concentrated load of 300kN, the joint load transfer capacity is unlikely to be exceeded.

 It is necessary for each application that the engineer determines from the loads on the slab what the load transfer requirement will be at the joint. It is also necessary to ensure that the load transfer requirement at the joint is within the Ultimate Load capability of the concrete and dowel system at the joint position.

 Please note that the figures shown in Table 1 relate to one specific set of slab factors only. We strongly recommend that for each slab design the engineer determines the load transfer requirement at the joint based on the loads on the slab and Permaban can recommend consulting engineering practices to assist with this. The engineer should also determine the Ultimate Load capability for the concrete and dowel system at the joint and Permaban can provide assistance with this.

Table 1: Theoretical calculated ultimate loads at failure of dowel or concrete

(For three typical slabs, 40N/mm² concrete strength and 20mm joint opening)

	Slab Thickness (mm)	Dowel Centres (mm)	ULTIMATE LOAD per DOWEL (kN)					ULTIMATE LOAD per METRE at joint (kN/m)	
			Dowel Limit			Concrete Limit			
			Shear	Bending	Combined Shear & Bending	Bearing	Bursting		
			Load transfer values for the GD8 plate dowel @ 600mm CRS & 20mm joint opening						20mm round dowel @600mm CRS
Non-reinforced concrete (Re3 Factor = 0)	150	600	188.3	69.7	71.2	81.7	30.6	51.0	42.0
	200	600	188.3	69.7	71.2	81.7	41.9	69.9	56.0
	250	600	188.3	69.7	71.2	81.7	46.0	76.7	70.0
Steel fibre reinforced concrete at 40kg/m ³ (Re3 Factor = 0.8)	150	600	188.3	69.7	71.2	81.7	52.8	88.0	72.5
	200	600	188.3	69.7	71.2	81.7	72.4	116.2	75.7
	250	600	188.3	69.7	71.2	81.7	77.6	116.2	75.7

Table 2: Joint Weights & Pack Sizes (approx.)

AlphaJoint C	120	130	140	150	160	180	200	225	250	275	300
Joints per bundle	30	30	30	30	25	25	21	17	17	17	13
Single 3m joint weight (kg)	22.5	23.0	23.4	23.9	24.4	25.3	26.3	27.4	28.6	29.8	31.0
Total bundle weight (kg)	760	774	788	802	695	718	630	545	565	585	481



PERMABAN LIMITED

Mill Close, Lee Mill Industrial Estate, Ivybridge, Devon PL21 9GL

t: +44 (0)1752 895288 f: +44 (0)1752 690535

Permaban Limited are registered in England - No. 02815314